

OVERLOAD PROTECTOR

超負荷保護裝置

OVERLOAD

OVERLOAD PROTECTOR

超負荷保護裝置

VA06M-760



VA08-760



VA12-760

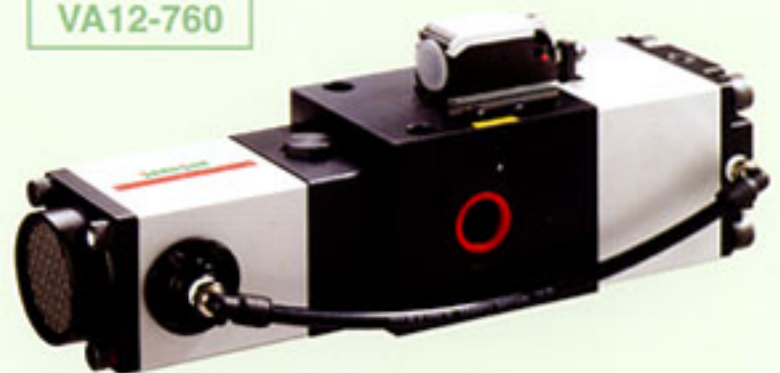

Function

- Overload protector is equipped in press machine to check the hydraulic pressure of cylinder inside the slider.
- If happen overload, the hydraulic pressure of cylinder will be released immediately within 3/1000 seconds.
- When happen overload, in order to protect the press and die, the press will stop working immediately after receiving the signal from limit switch.
- After happen overload, the air will drive hydraulic pump to supplement normal working pressure immediately and the press can work normally.
- It has pressure control valve inside of overload protector, which can adjust hydraulic pressure automatically and eliminate the impact of rising pressure (which cause by oil temperature rise) in pressing process.

功能

- 超負荷保護裝置是安裝使用於沖床上，用以檢知滑塊油壓缸內部的超負荷油壓壓力。
- 當超負荷情形發生時，使油壓壓力能在千分之三秒內迅速被洩放。
- 超負荷發生時，微動開關產生電氣信號，通知沖床緊急停止運轉，以保護沖床和模具。
- 超負荷發生後，由空氣驅動油壓泵浦，快速補足油壓缸的正常工作壓力，使沖床能立即正常操作。
- 超負荷保護裝置內部具有恆壓控制閥，能自動調節油壓壓力，可消除沖床在沖壓過程中，因油溫上升時而產生壓力上升所受的影響。

VS06M-760



VS08-760



VS12-760



Model Selection / 型式選用 : V 1 2 3 4 - 5 6 7 8 - 9

1	Control type 控制方式	A : Air pressure control S : Spring adjust
2	Suitable for capacity of press 適用沖床噸數	06 : 200 tons & down 08 : 200 tons & down 10 : 200 tons & down 12 : 200~600 tons
3	Ratio of pump pressure 泵浦油壓出力	Empty (Standard type) : 22 ratio M : 32 ratio H : 42 ratio
4	Design No. 設計變更碼	Empty : First edition A~Z : Revise edition
5	Ratio of overload pressure 超負荷壓力倍比	5 : x 50 ratio 7 : x 70 ratio 9 : x 90 ratio
6	Position of limit switch (type) 微動開關(型式)	2 : NO type 6 : NC type
7	Volume of oil tank (Liter) 油箱容量	0 : None 3 : 4.0 ℓ 1 : 1.2 ℓ 5 : 8.0 ℓ
8	Control unit 控制單元	Empty : None C : Include
9	Pressure setting (kgf/cm ²) 壓力設定值	VA Model : None VS Model : ex. 3 0 0 is 300 kgf/cm ²

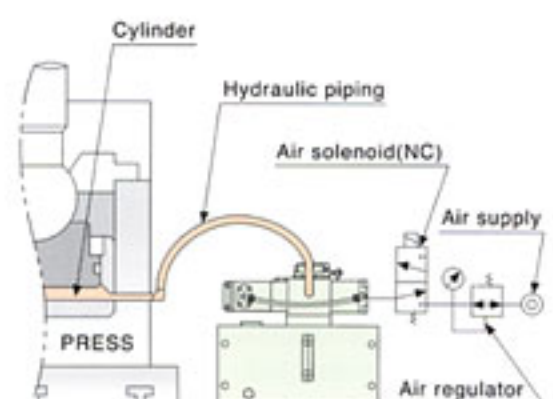
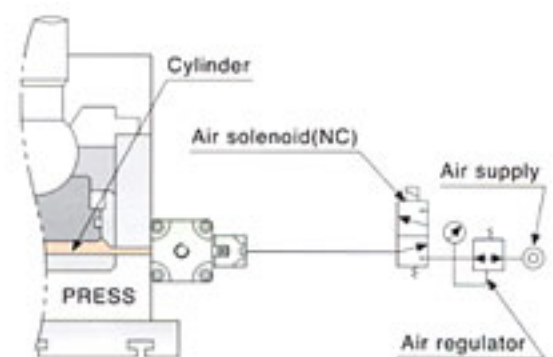

AIR PRESSURE CONTROL SERIES

系列產品

Model **VA08**

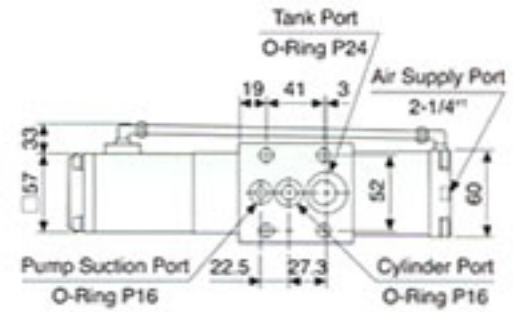
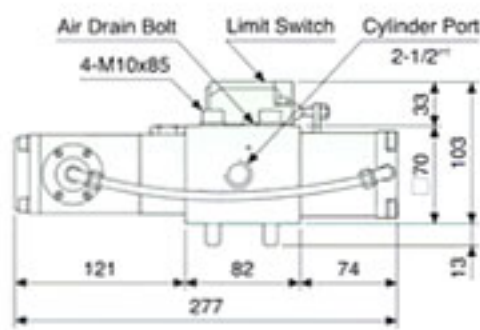

Include Oil Tank / 含油箱

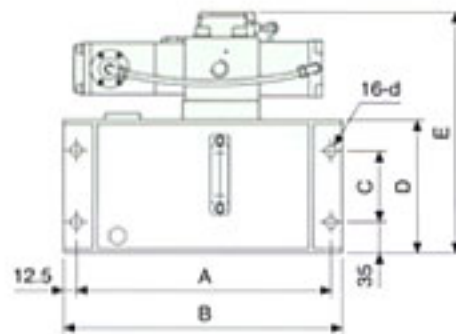

Installation Dimensions 安裝配合尺寸

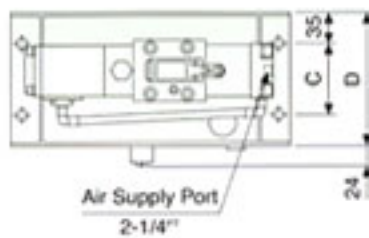
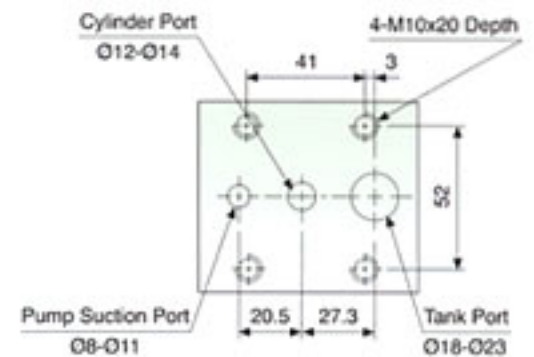

Model	A	B	C	D	E	d	Volume
VA08-□□1	206	230	50	100	226	Ø11	1.2 l
VA08-□□3	285	310	80	150	276	Ø13	4.0 l
VA08-□□5	355	380	130	200	326	Ø13	8.0 l

Model/型式	Releasing flow rate 洩放流量 (cm ³ /sec)	Area of orifice 制流孔面積 (cm ²)	Pressure setting 壓力設定方式	Pressure setting range 壓力設定範圍 (kgf/cm ²)	Air supply 使用空氣壓力 (kgf/cm ²)
VA08-560	15500	0.7	Air pressure x 50 ratio	150 ~ 250	3 ~ 5
VA08-760	13000	0.5	Air pressure x 70 ratio	210 ~ 350	
VA08-960	11500	0.4	Air pressure x 90 ratio	270 ~ 450	
VA08M-760	13000	0.5	Air pressure x 70 ratio	210 ~ 350	
VA08M-960	11500	0.4	Air pressure x 90 ratio	270 ~ 450	
VA08H-760	13000	0.5	Air pressure x 70 ratio	280 ~ 350	
VA08H-960	11500	0.4	Air pressure x 90 ratio	270 ~ 450	

- Suitable for press tons : 200 tons & down / 適用沖床 : 200 噸 (含) 以下
- Air consumption : 220(Nl/min) / 空氣消耗量
- Max. noise : 77(dB) / 音量
- Hydraulic oil : ISO-VG-32 or equivalent / 使用液壓油

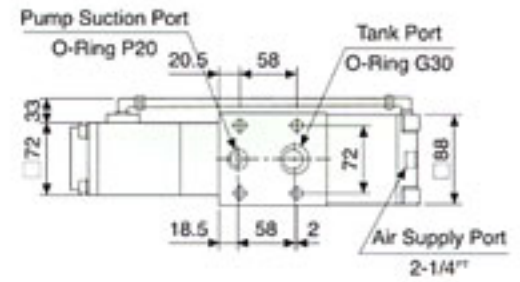
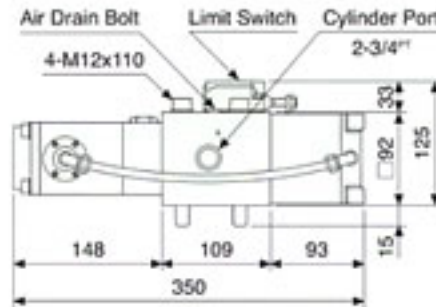

Include Oil Tank / 含油箱

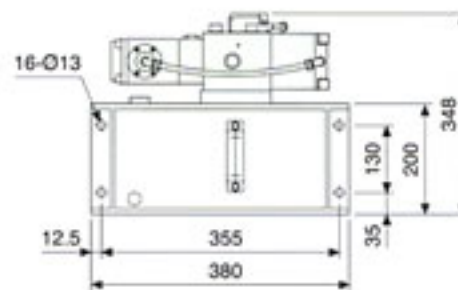

Installation Dimensions 安裝配合尺寸

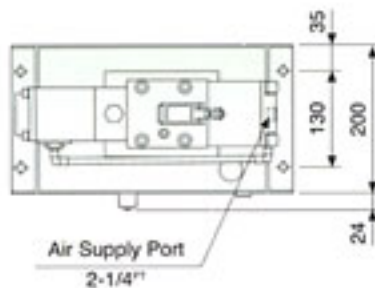
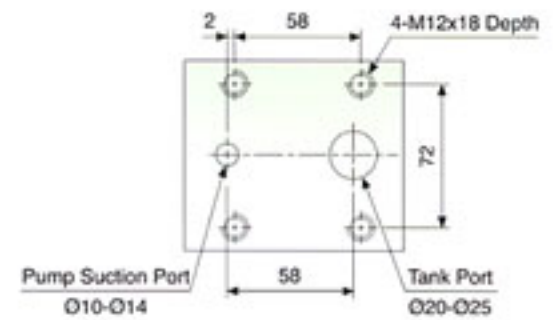

Model 型式	Releasing flow rate (cm ³ /sec) 洩放流量	Area of orifice 制流孔面積 (cm ²)	Pressure setting 壓力設定方式	Pressure setting range (kgf/cm ²) 壓力設定範圍	Air supply 使用空氣壓力 (kgf/cm ²)
VA12-560	39000	1.7	Air pressure x 50 ratio	150 ~ 250	3 ~ 5
VA12-760	31000	1.2	Air pressure x 70 ratio	210 ~ 350	
VA12-960	27000	0.93	Air pressure x 90 ratio	270 ~ 450	
VA12H-760	31000	1.2	Air pressure x 70 ratio	210 ~ 350	
VA12H-960	27000	0.93	Air pressure x 90 ratio	270 ~ 450	

- Suitable for press tons : 200 ~ 600 tons / 適用沖床 : 200 ~ 600 噸
- Air consumption : 460(Nl/min) / 空氣消耗量
- Max. noise : 89(dB) / 音量

Include Control Unit / 含控制單元

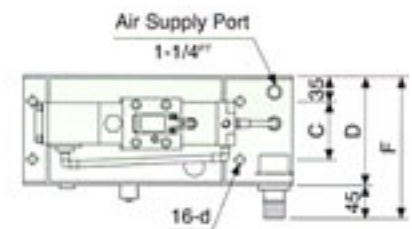
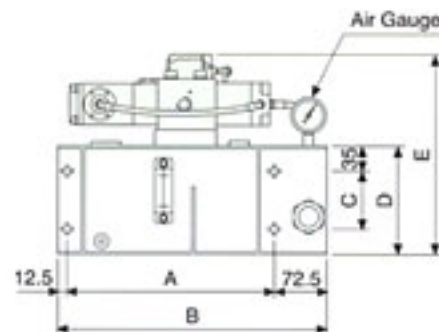

Model	A	B	C	D	E	F	d	Volume
VA08-□□3C	285	370	80	150	276	195	Ø13	4.0 l
VA12-□□5C	355	440	130	200	348	245	Ø13	8.0 l

- Control unit : include pressure regulation valve, solenoid valve, pressure gauge
控制單元 : 含調壓閥、電磁閥及壓力計

SPRING CONTROL SERIES

系列產品

Model **VS08**

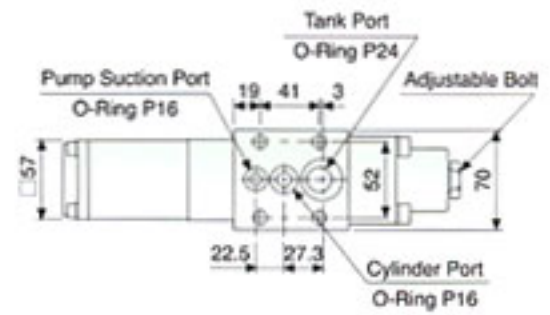
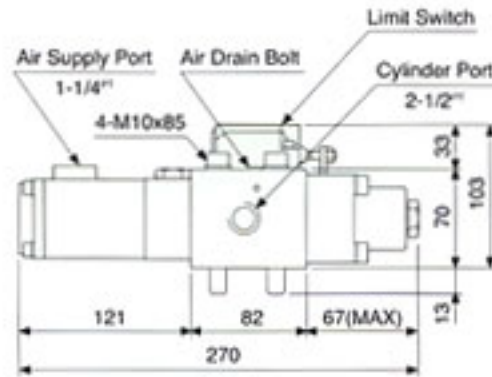

Include Oil Tank / 含油箱

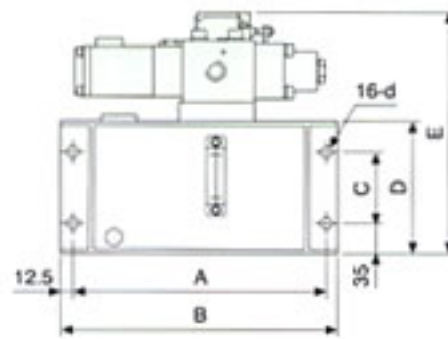

Installation Dimensions 安裝配合尺寸

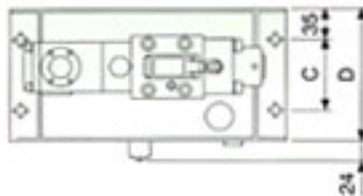
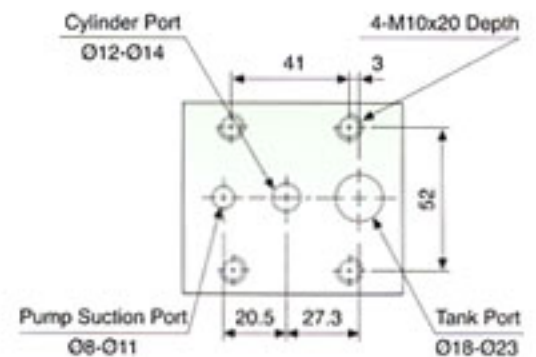

Model	A	B	C	D	E	d	Volume
VS08-□□1	206	230	50	100	226	Ø11	1.2 l
VS08-□□3	285	310	80	150	276	Ø13	4.0 l
VS08-□□5	355	380	130	200	326	Ø13	8.0 l

Model/型式	Releasing flow rate 洩放流量 (cm ³ /sec)	Area of orifice 制流孔面積 (cm ²)	Pressure setting 壓力設定方式	Pressure setting range 壓力設定範圍 (kgf/cm ²)	Air supply 使用空氣壓力 (kgf/cm ²)
VS08-560	15500	0.7	Spring adjust	150 ~ 250	3 ~ 5
VS08-760	13000	0.5		210 ~ 350	
VS08-960	11500	0.4		270 ~ 450	
VS08M-760	13000	0.5		210 ~ 350	
VS08M-960	11500	0.4		270 ~ 450	
VS08H-760	13000	0.5		250 ~ 350	
VS08H-960	11500	0.4		270 ~ 450	
VS10A-760	18000	0.7		210 ~ 350	
VS10M-760	18000	0.7		210 ~ 350	
VS10H-760	18000	0.7		250 ~ 350	

- Suitable for press tons : 200 tons & down / 適用沖床 : 200 噸 (壹) 以下
- Air consumption : 220(Nl/min) / 空氣消耗量
- Max. noise : 77(dB) / 音量
- Hydraulic oil : ISO-VG-32 or equivalent / 使用液壓油

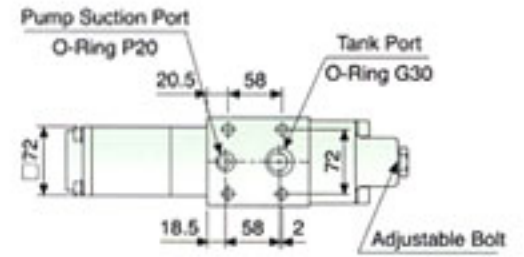
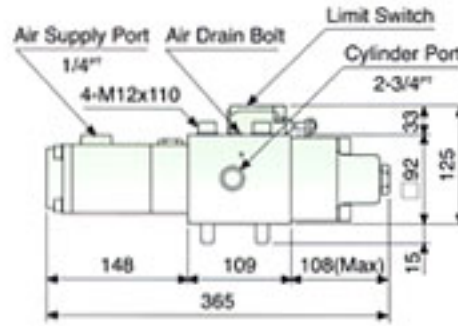

Include Oil Tank / 含油箱

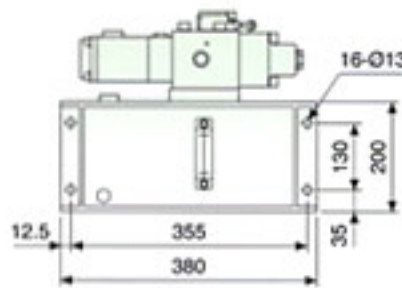

**Installation Dimensions
安裝配合尺寸**

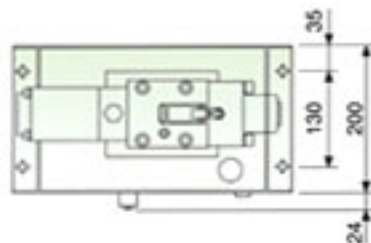
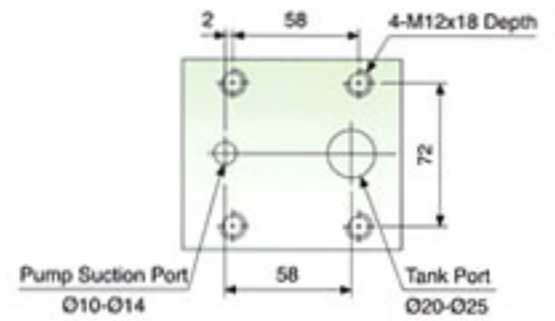

Model 型式	Releasing flow rate (cm ³ /sec) 洩放流量	Area of orifice 制流孔面積 (cm ²)	Pressure setting 壓力設定方式	Pressure setting range (kgf/cm ²) 壓力設定範圍	Air supply 使用空氣壓力 (kgf/cm ²)
VS12-560	39000	1.7	Spring adjust	150 ~ 250	3 ~ 5
VS12-760	31000	1.2		210 ~ 350	
VS12-960	27000	0.93		270 ~ 450	
VS12H-760	31000	1.2		250 ~ 350	
VS12H-960	27000	0.93		270 ~ 450	

- Suitable for press tons : 200 ~ 600 tons / 適用沖床 : 200 ~ 600 噸
- Air consumption : 460(Nl/min) / 空氣消耗量
- Max. noise : 89(dB) / 音量

Include control unit / 含控制單元

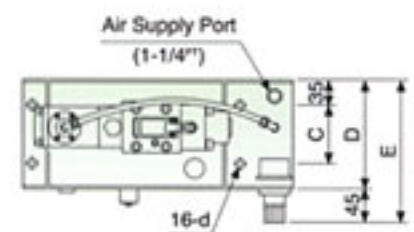
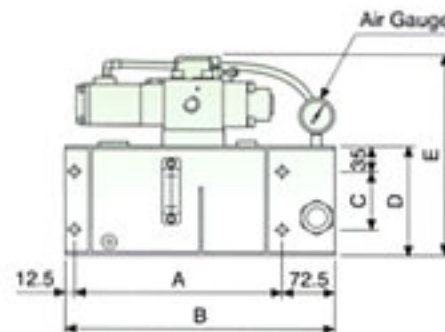

Model	A	B	C	D	E	F	d	Volume
VS08-□□3C	285	370	80	150	276	195	Ø13	4.0 l
VS12-□□5C	355	440	130	200	348	245	Ø13	8.0 l

- Control unit : include pressure regulation valve, solenoid valve, pressure gauge
控制單元 : 含調壓閥、電磁閥及壓力計

AIR PRESSURE SPRING CONTROL SERIES / 系列產品

Model **VA06M / VS06M**

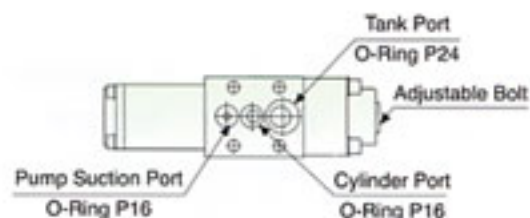
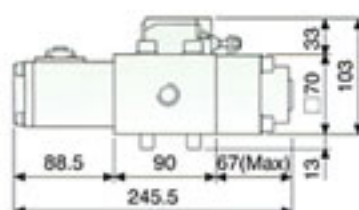
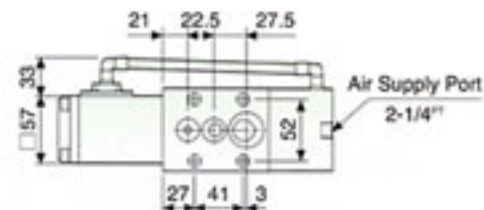
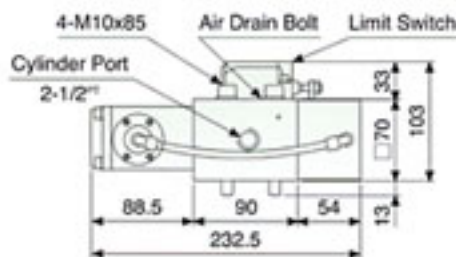

Include Oil Tank / 含油箱

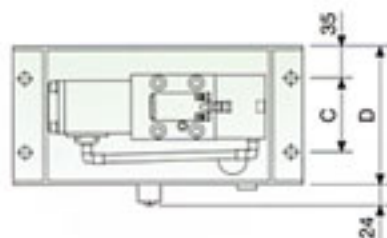
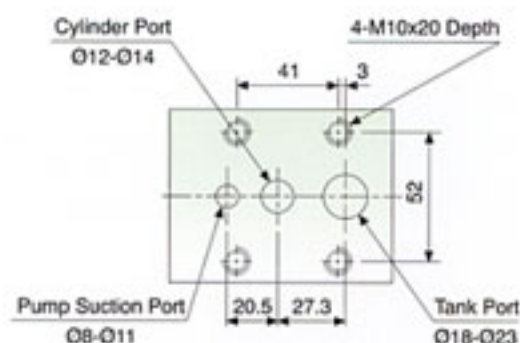
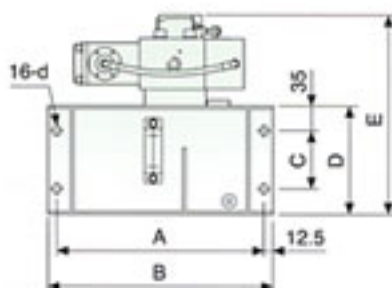

Model	A	B	C	D	E	d	Volume
VA06M-□□1 VS06M-□□1	206	230	50	100	226	Ø11	1.2 ℓ
VA06M-□□3 VS06M-□□3	285	310	80	150	276	Ø13	4.0 ℓ

Model / 型式	Releasing flow rate 洩放流量 (cm ³ /sec)	Area of orifice 制流孔面積 (cm ²)	Pressure setting 壓力設定方式	Pressure setting range 壓力設定範圍 (kgf/cm ²)	Air supply 使用空氣壓力 (kgf/cm ²)
VA06M-760	13000	0.5	Air pressure	210 ~ 350	3 ~ 5
VA06M-960	11500	0.4		270 ~ 450	
VS06M-760	13000	0.5	Spring adjust	210 ~ 350	
VS06M-960	11500	0.4		270 ~ 450	

- Suitable for press tons : 200 tons & down / 適用沖床 : 200 噸 (含) 以下
- Air consumption : 220(Nl/min) / 空氣消耗量
- Max. noise : 77(dB) / 音量
- Hydraulic oil : ISO-VG-32 or equivalent / 使用液壓油

Selection Basis / 選用依據

• Specification & Parameter of Press 沖床規格參數：

- F : press rated capacity 沖床能力 (tons)
- S : stroke length 滑塊行程(mm)
- N : stroke per minute 每分鐘行程數(SPM)
- H : rated tonnage point 能力發生點(mm)
- D : cylinder diameter 油缸直徑(cm)
- n : cylinder number 油缸個數(pc)
- h : cylinder stroke 油缸之活塞行程(cm)
- m : ratio of overload hydraulic pressure 超負荷壓力倍數

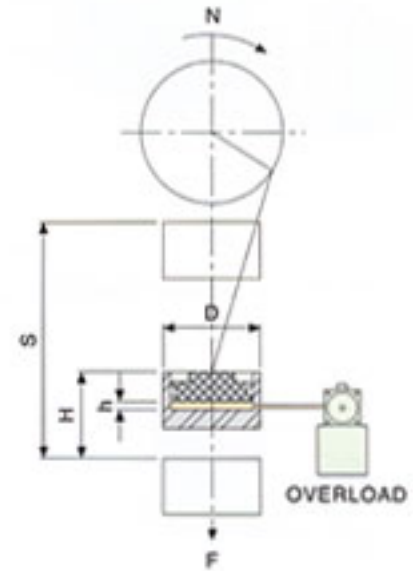

• Calculation Formulas for Model Selection 型式選用計算流程：

- $A = (\pi D^2/4) \times n$ (cm²) cylinder area 油缸面積
- $P = F \times 1.1 \times 1000 / A$ (kgf/cm²) hydraulic pressure setting of overload (VS model) 超負荷設定的油壓壓力
- $P_a = P / m$ (kgf/cm²) air pressure setting of overload (VA model) 超負荷設定的空氣壓力
- $V = N \sqrt{SH - H^2} / 87.5$ (cm/sec) drop speed of slide 滑塊下降速度
- $Q = A \times V$ (cm³/sec) releasing flow rate 超負荷發生時的洩放流量
- $L \geq 4 \times A \times h$ (cm³) volume of oil tank 油箱容量

※ Releasing flow rate (Q) of overload protector, which you choose has to be more than of cylinder volume.
If releasing flow rate isn't enough, please use two sets of overload protector.

• Example 範例：(model:VA(VS)08-7□□)

- F = 160 tons $A = (\pi 26^2/4) \times 1 = 531$ (cm²)
- S = 200 mm $P = 160 \times 1.1 \times 1000 / 531 \approx 332$ (kgf/cm²) -----VS model
- N = 40 SPM $P_a = 332 / 70 \approx 4.75$ (kgf/cm²) -----VA model
- H = 6 mm $V = 40 \sqrt{200 \times 6 - 6^2} / 87.5 = 15.6$ (cm/sec)
- D = 26 cm $Q = 531 \times 15.6 = 8284$ (cm³/sec)
- n = 1 pc $L \geq 4 \times 531 \times 1 \geq 2120$ (cm³)
- h = 1 cm

Note

1. Hydraulic pressure (P) and air pressure (Pa) of overload protector, should be choose as higher as possible.
(Example : P=335 kgf/cm² or Pa=4.8 kgf/cm²)
2. Hydraulic piping size :

VA (VS) 08 - □□□ - □□□		VA (VS) 12 - □□□ - □□□	
Size (I.D./O.D.)	Work pressure (maxi.)	Size (I.D./O.D.)	Work pressure (maxi.)
12/18 mm	400 kgf/cm ²	14/22 mm	400 kgf/cm ²
13/18 mm	320 kgf/cm ²	16/22 mm	300 kgf/cm ²
14/18 mm	250 kgf/cm ²	18/22 mm	200 kgf/cm ²

3. Inside diameter of air piping must be more than 6 mm.

ISO 9001 CE

MANAGING PHILOSOPHY: MODERATE & RELIABLE · AGGRESSIVE & CREATIVE
DEMANDING FOR PERFECTION · CONSTANT OPERATION

QUALITY POLICY: QUALITY STABILITY · CUSTOMER SATISFACTION

經營理念：穩健踏實、精進創新、止於至善、永續經營。

品質政策：品質穩定、客戶肯定。



山田順精機股份有限公司

SANDSUN PRECISION MACHINERY CO., LTD.

台灣省彰化縣大村鄉中山路三段57巷7號
NO. 7, LANE 57, SEC. 3, CHUNG-SHAN RD., DAH-TSUEN,
CHANG-HWA, TAIWAN.

<http://www.sandsun.com.tw>

E-mail: sandsun@ms26.hinet.net

sandsun@seed.net.tw

TEL:886-4-8536688 FAX:886-4-8536699

東莞服務處

東莞市虎門鎮東風管理區東北村新區二路

TEL:0769-85569867 FAX:0769-85569867

昆山服務處

江蘇省昆山市千燈鎮善浦新村

TEL:0512-57115782 FAX:0512-57115782